

Disc brake

Technical data and dimensions

Gear coupling disc association

Gear coupling type **SDF-MLP** for solid discs (**P**)

diameter from 315 to 995 mm

Gear coupling type **SDF-MLV** for ventilated discs (**V**)

diameter from 315 to 795 mm.

Long hub on disc side / Discs thickness 30 mm.

Disc mounting and dismantling without moving the machines back.

Material and balancing of the discs : see the discs "technical data" leaflet quoted in the bottom of the page.

Hub and coupling : oiling protection.

In standard, only the disc is balanced.

The assembly is balanced on demand, (parts angularly matched).

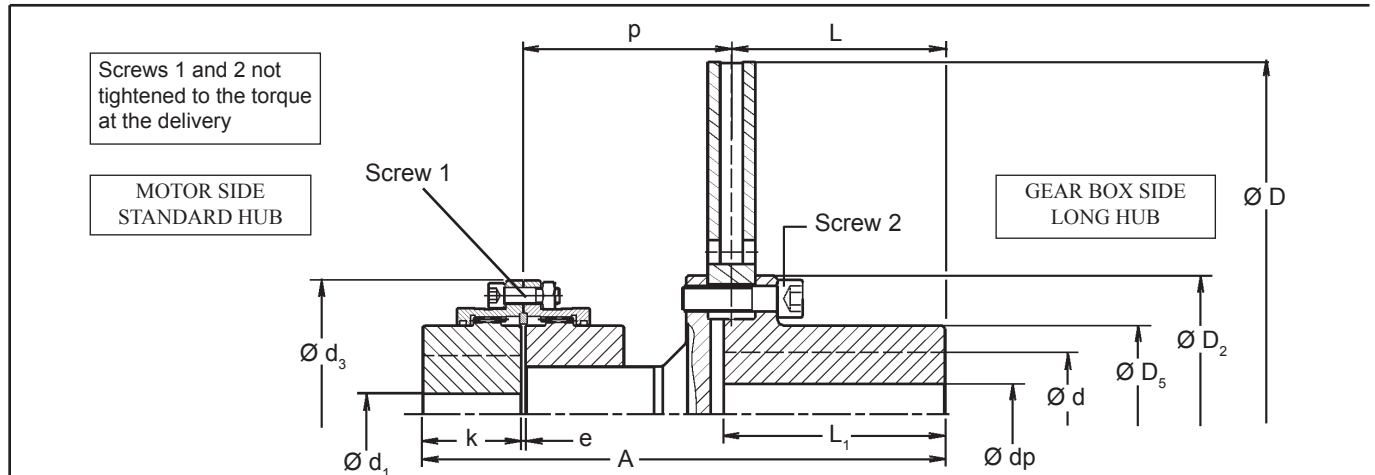

Degrease faces in contact between disc, hub and coupling

Designation			Disc	315 P30/V30		355 P30/V30		395 P30/V30		445 P30/V30								
				SDF		68		68		68		80		100				
Assembly	J	P30	V30	kg.m ²	0,245	0,159	0,396	0,26	0,606	0,37	0,624	0,388	0,95	0,591	0,969	0,61	1,019	0,66
	Weight	P30	V30	kg	34,2	27,2	43	34	52,5	41,5	59,1	48,1	62,1	47,1	69,2	54,2	79,8	64,8
	A	mm			307	327		327		339		367		392		421		
	Maximum speed	rpm			3000	2700		2400		2100								
	Maximum braking torque	N.m			T _b ≤ T _p (T _b = maximum braking torque, T _p = maximum peak torque)													
For use with calipers				Check that D – D ₂ > width of the caliper braking surface (ex.: 4CA and 3CA not associated to discs D < 445) Check that the caliper nominal braking torque is ≤ T _p														
Disc	D	mm		315	355		395		445									
	D ₂	mm		125	145		165		175									
	D ₅	mm		80	100		112		112									
	L	mm		135	155		155		195									
	L ₁	mm		140	160		160		200									
	dp	mm		--	--		--		--									
	d maximum keyed	mm		55	70		75		80									
	d max. shrink fit	mm		50	60		70		70									
Tightening torque screw 2 *	N.m		49	86		135		210										
Coupling	d ₃	mm		140	140		140		169		140		169		200			
	e	mm		3	3		3		3		3		3		5			
	k	mm		50	50		50		62		50		62		76			
	p	mm		120,5	120,5		120,5		120,5		120,5		133,5		147,5			
	d ₁ maximum keyed	mm		68	68		68		80		68		80		100			
	d ₁ max. shrink fit	mm		63	63		63		75		63		75		92			
	Tightening torque screws 1 *	N.m		33	33		33		60		33		60		60			
	Maximum peak torque (T _p)	N.m		1500	2200		2200		2200		2200		3800		6000			
	Transmissible torque (T _t)	N.m		750	1100		1100		1100		1100		1900		3000			
	In every case : T _s < T _p (T _s : motor starting torque)																	

*: greased under head and on thread

Due to continuous development and improvement, all dimensions and characteristics are subject to change without notice

Installation and maintenance	Leaflets No. M10004-01	07/01/14	1/5
Technical data SDF	No. T10004-01		
Technical data SMLDF	No. T10004-03		
Technical data SMLDF-ML	No. T10004-04		
Technical data discs	No. T08020-01		
T10004-02-F			

Disc brake

Technical data and dimensions

Gear coupling disc association

Gear coupling type **SDF-MLP** for solid discs (**P**)

diameter from 315 to 995 mm

Gear coupling type **SDF-MLV** for ventilated discs (**V**)

diameter from 315 to 795 mm.

Long hub on disc side / Discs thickness 30 mm.

Disc mounting and dismantling without moving the machines back.

Material and balancing of the discs : see the discs "technical data" leaflet quoted in the bottom of the page.

Hub and coupling : oiling protection.

In standard, only the disc is balanced.

The assembly is balanced on demand, (parts angularly matched).

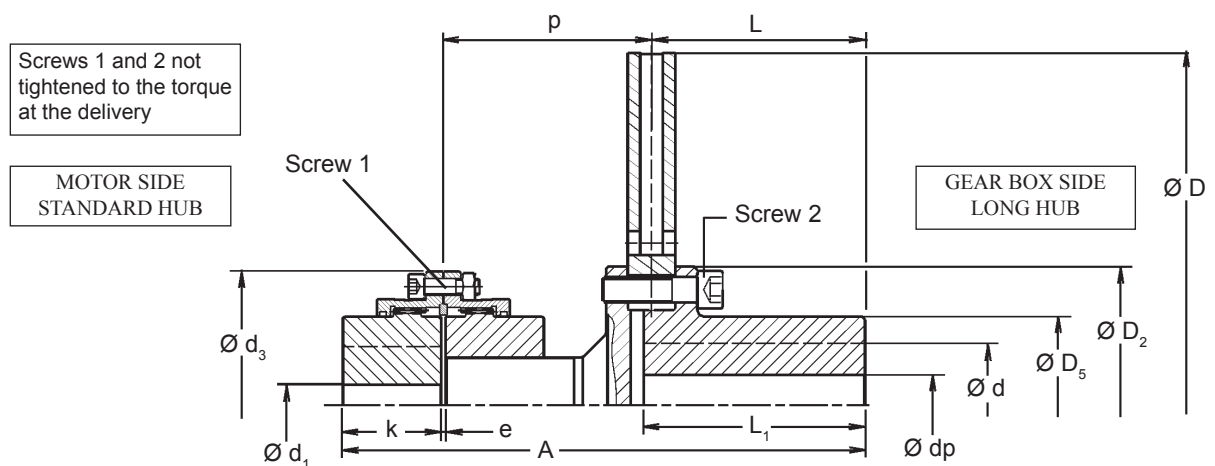

Degrease faces in contact between disc, hub and coupling

Designation		Disc SDF	495 P30/V30						550 P30/V30							
			80		100		115		80		100		115			
Assembly	J	P30	V30	kg.m ²	1,547	1,023	1,599	1,075	1,688	1,164	2,27	1,33	2,322	1,382	2,411	1,471
	Weight	P30	V30	kg	96,1	78,1	108,1	90,1	122,2	104,2	107,1	84,1	119,1	96,1	133,2	110,2
	A			mm	407		440		470		407		440		470	
	Maximum speed			rpm	1900						1800					
	Maximum braking torque			N.m	T _b ≤ T _p (T _b = maximum braking torque, T _p = maximum peak torque)											
For use with calipers			Check that D – D ₂ > width of the caliper braking surface (ex.: 4CA and 3CA not associated to discs D < 445) Check that the caliper nominal braking torque is ≤ T _p													
Disc	D			mm	495						550					
	D ₂			mm	218						218					
	D ₅			mm	155						155					
	L			mm	195						195					
	L ₁			mm	200						200					
	dp			mm	30						30					
	d maximum keyed			mm	110						110					
	d max. shrink fit			mm	100						100					
Tightening torque screw 2 *			N.m	290						290						
Coupling	d ₃			mm	169	200	228	169	200	228	169	200	228	169	200	228
	e			mm	3	5	5	3	5	5	3	5	5	3	5	5
	k			mm	62	76	90	62	76	90	62	76	90	62	76	90
	p			mm	148,5	166,5	182,5	148,5	166,5	182,5	148,5	166,5	182,5	148,5	166,5	182,5
	d ₁ maximum keyed			mm	80	100	115	80	100	115	80	100	115	80	100	115
	d ₁ max. shrink fit			mm	75	92	106	75	92	106	75	92	106	75	92	106
	Tightening torque screws 1 *			N.m	60	60	95	60	60	95	60	60	95	60	60	95
	Maximum peak torque (T _p)			N.m	3800	6000	9400	3800	6000	9400	3800	6000	9400	3800	6000	9400
	Transmissible torque (T _t)			N.m	1900	3000	4700	1900	3000	4700	1900	3000	4700	1900	3000	4700
	In every case : T _s < T _p (T _s : motor starting torque)															

*: greased under head and on thread

Due to continuous development and improvement, all dimensions and characteristics are subject to change without notice

Installation and maintenance	Leaflets No. M10004-01	07/01/14	2/5
Technical data SDF	No. T10004-01	T10004-02-F	
Technical data SMLDF	No. T10004-03		
Technical data SMLDF-ML	No. T10004-04		
Technical data discs	No. T08020-01		

Disc brake

Technical data and dimensions

Gear coupling disc association

Gear coupling type **SDF-MLP** for solid discs (**P**)

diameter from 315 to 995 mm

Gear coupling type **SDF-MLV** for ventilated discs (**V**)

diameter from 315 to 795 mm.

Long hub on disc side / Discs thickness 30 mm.

Disc mounting and dismantling without moving the machines back.

Material and balancing of the discs : see the discs "technical data" leaflet quoted in the bottom of the page.

Hub and coupling : oiling protection.

In standard, only the disc is balanced.

The assembly is balanced on demand, (parts angularly matched).

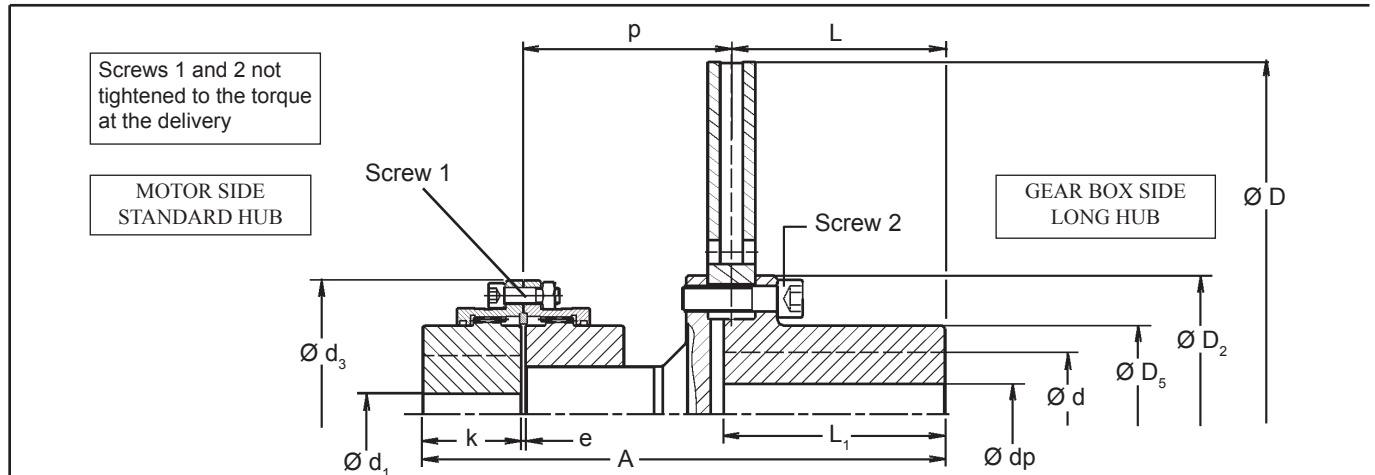

Degrease faces in contact between disc, hub and coupling

Designation			Disc SDF	625 P30/V30				625-2 P30/V30										
				100	115	135	150	150	170	190								
Assembly	J	P30	V30	kg.m ²	3,806	2,36	3,843	2,397	4,11	2,664	4,431	2,985	4,735	3,289	5,286	3,84	6,028	4,582
	Weight	P30	V30	kg	142,5	115,5	157	130	186,1	159,1	219,3	192,3	245,2	218,2	290,6	263,6	307,5	280,5
	A	mm			440	470	501	543	543	573	585							
	Maximum speed	rpm			1500				1200									
	Maximum braking torque	N.m			Tb ≤ Tp (Tb = maximum braking torque, Tp = maximum peak torque)													
For use with calipers				Check that D – D2 > width of the caliper braking surface (ex.: 4CA and 3CA not associated to discs D < 445) Check that the caliper nominal braking torque is ≤ Tp														
Disc	D	mm		625				625										
	D2	mm		238				300										
	D5	mm		168				216										
	L	mm		195				195										
	L1	mm		200				200										
	dp	mm		30				30										
	d maximum keyed	mm		120				150										
	d max. shrink fit	mm		105				135										
Tightening torque screw 2 *				N.m				410				710						
Coupling	d3	mm		200	228	266	298	298	330	368								
	e	mm		5	5	6	6	6	8	8								
	k	mm		76	90	105	120	120	135	150								
	p	mm		166,5	182,5	198	225	225	239	236								
	d1 maximum keyed	mm		100	115	135	150	150	170	190								
	d1 max. shrink fit	mm		92	106	125	140	140	160	175								
	Tightening torque screws 1 *				N.m				60	95	171	235	235	235	370			
	Maximum peak torque (Tp)				N.m				6000	9400	13800	20700	25300	36700	52500			
	Transmissible torque (Tt)				N.m				3000	4700	6900	10350	12650	18350	26250			
	In every case : Ts < Tp (Ts : motor starting torque)																	

*: greased under head and on thread

Due to continuous development and improvement, all dimensions and characteristics are subject to change without notice

Disc brake

Technical data and dimensions

Gear coupling disc association

Gear coupling type **SDF-MLP** for solid discs (**P**)
 diameter from 315 to 995 mm
 Gear coupling type **SDF-MLV** for ventilated discs (**V**)
 diameter from 315 to 795 mm.
 Long hub on disc side / Discs thickness 30 mm.
 Disc mounting and dismantling without moving the
 machines back.

Material and balancing of the discs : see the discs "technical
 data" leaflet quoted in the bottom of the page.
 Hub and coupling : oiling protection.
 In standard, only the disc is balanced.
 The assembly is balanced on demand, (parts angularly
 matched).

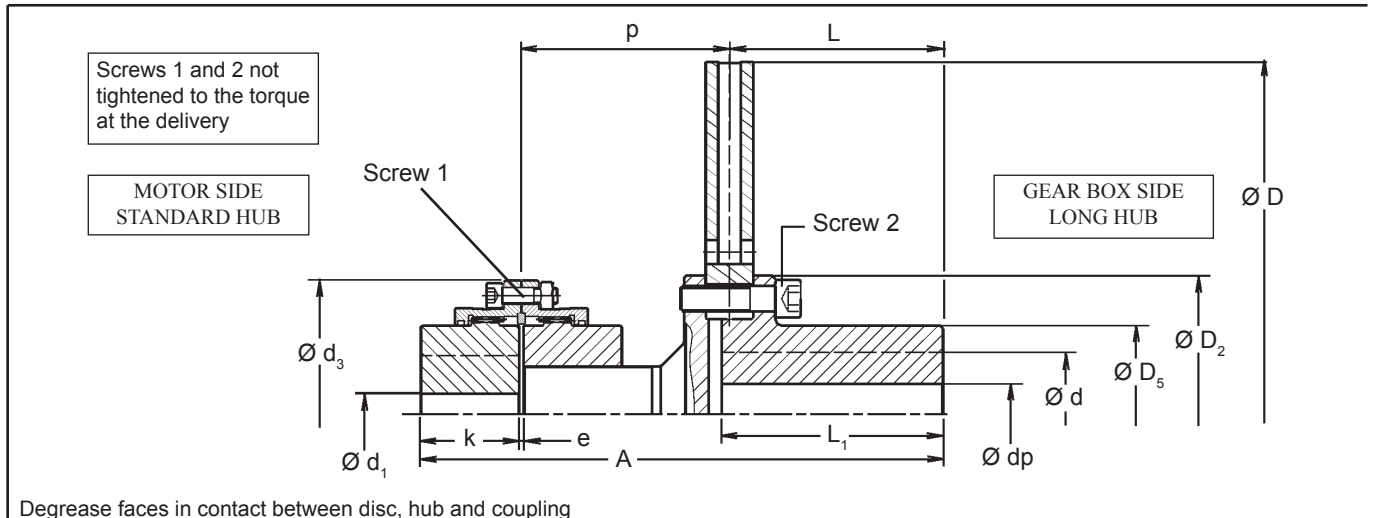

Degrease faces in contact between disc, hub and coupling

Designation		Disc SDF	705 P30/V30				705-2 P30/V30										
			115	135	150	170	150	170	190								
Assembly	J	P30 V30	kg.m ²	6,151	3,921	6,448	4,218	6,739	4,509	7,271	5,041	6,905	4,675	7,456	5,226	8,198	5,968
	Weight	P30 V30	kg	191,1	158,1	220,4	187,4	250,6	217,6	292,4	259,4	264,7	231,7	310,1	277,1	327	294
	A		mm	470	501	543	573	543	573	585							
	Maximum speed		rpm	1300				1200									
	Maximum braking torque		N.m	Tb ≤ Tp (Tb = maximum braking torque, Tp = maximum peak torque)													
For use with calipers			Check that D – D2 > width of the caliper braking surface (ex.: 4CA and 3CA not associated to discs D < 445) Check that the caliper nominal braking torque is ≤ Tp														
Disc	D		mm	705				705									
	D2		mm	268				300									
	D5		mm	190				216									
	L		mm	195				195									
	L1		mm	200				200									
	dp		mm	30				30									
	d maximum keyed		mm	135				150									
	d max. shrink fit		mm	120				135									
Tightening torque screw 2 *		N.m	550				710										
Coupling	d3		mm	228	266	298	330	298	330	368							
	e		mm	5	6	6	8	6	8	8							
	k		mm	90	105	120	135	120	135	150							
	p		mm	182,5	198	225	239	225	239	236							
	d1 maximum keyed		mm	115	135	150	170	150	170	190							
	d1 max. shrink fit		mm	106	125	140	160	140	160	175							
	Tightening torque screws 1 *		N.m	95	171	235	235	235	235	370							
	Maximum peak torque (Tp)		N.m	9400	13800	25300	29200	25300	36700	52500							
	Transmissible torque (Tt)		N.m	4700	6900	12650	14600	12650	18350	26250							
	In every case : Ts < Tp (Ts : motor starting torque))																

*: greased under head and on thread

Due to continuous development and improvement, all dimensions and characteristics are subject to change without notice

Installation and maintenance	Leaflets No. M10004-01	07/01/14	4/5
Technical data SDF	No. T10004-01	T10004-02-F	
Technical data SMLDF	No. T10004-03		
Technical data SMLDF-ML	No. T10004-04		
Technical data discs	No. T08020-01		

Disc brake

Technical data and dimensions

Gear coupling disc association

Gear coupling type **SDF-MLP** for solid discs (**P**)

diameter from 315 to 995 mm

Gear coupling type **SDF-MLV** for ventilated discs (**V**)

diameter from 315 to 795 mm.

Long hub on disc side / Discs thickness 30 mm.

Disc mounting and dismantling without moving the machines back.

Material and balancing of the discs : see the discs "technical data" leaflet quoted in the bottom of the page.

Hub and coupling : oiling protection.

In standard, only the disc is balanced.

The assembly is balanced on demand, (parts angularly matched).

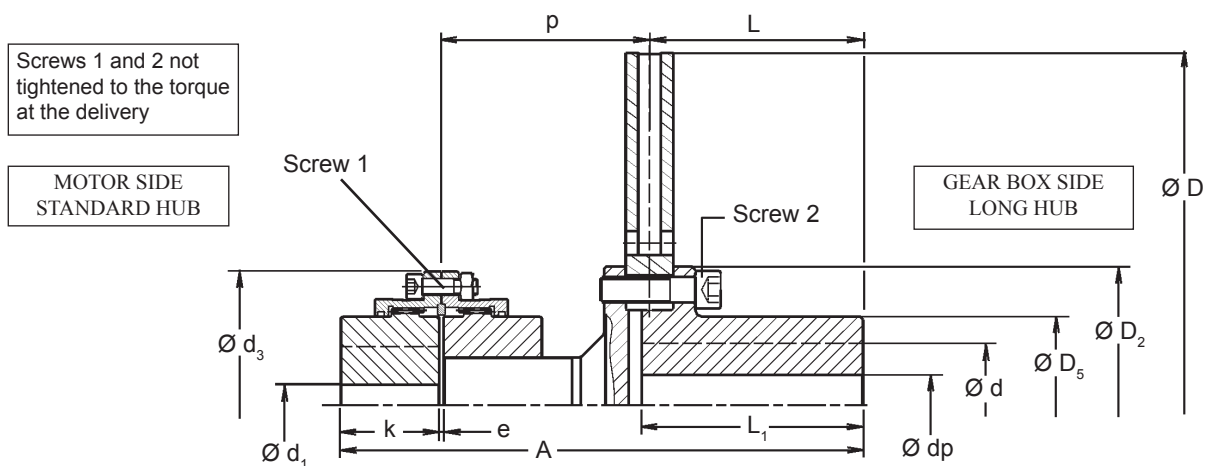

Degrease faces in contact between disc, hub and coupling

Designation				Disc	795 P30/V30								995P30			
				SDF	135		150		170		190		150	170	190	
Assembly	J	P30	V30	kg.m ²	10,213	6,633	10,515	6,935	11,066	7,486	11,808	8,228	25,08	25,623	26,54	
	Weight	P30	V30	kg	261,6	221,6	292,2	252,2	337,6	297,6	354,5	314,5	424,7	451,1	505,2	
	A			mm	501		543		573		585		595	610	650	
	Maximum speed			rpm	1200										900	
	Maximum braking torque			N.m	Tb ≤ Tp (Tb = maximum braking torque, Tp = maximum peak torque)											
For use with calipers					Check that D – D2 > width of the caliper braking surface (ex.: 4CA and 3CA not associated to discs D < 445) Check that the caliper nominal braking torque is ≤ Tp											
Disc	D			mm	795										995	
	D2			mm	300										388	
	D5			mm	216										276	
	L			mm	195										235	
	L1			mm	200										240	
	dp			mm	30										58	
	d maximum keyed			mm	150										190	
	d max. shrink fit			mm	135										180	
Tightening torque screw 2 *				N.m	710										1450	
Coupling	d3			mm	266	298	330	368	298	330	368	298	330	368		
	e			mm	6	6	8	8	6	8	8	6	8	8		
	k			mm	105	120	135	150	120	135	150	120	135	150		
	p			mm	198	225	239	236	237	236	261	237	236	261		
	d1 maximum keyed			mm	135	150	170	190	150	170	190	150	170	190		
	d1 max. shrink fit			mm	125	140	160	175	140	160	175	140	160	175		
	Tightening torque screws 1 *				N.m	171	235	235	370	235	235	370	235	235	370	
	Maximum peak torque (Tp)				N.m	13800	25300	36700	52500	29200	38000	52500	29200	38000	52500	
	Transmissible torque (Tt)				N.m	6900	12650	18350	26250	14600	19000	26250	14600	19000	26250	

In every case : Ts < Tp (Ts : motor starting torque)

*: greased under head and on thread

Due to continuous development and improvement, all dimensions and characteristics are subject to change without notice

Installation and maintenance	Leaflets No. M10004-01	7/01/14	5/5
Technical data SDF	No. T10004-01	T10004-02-F	
Technical data SMLDF	No. T10004-03		
Technical data SMLDF-ML	No. T10004-04		
Technical data discs	No. T08020-01		